**UNITED STATES
SECURITIES AND EXCHANGE COMMISSION
WASHINGTON, D.C. 20549**

FORM 8-K

**CURRENT REPORT
PURSUANT TO SECTION 13 OR 15(D)
OF THE SECURITIES EXCHANGE ACT OF 1934**

Date of report (Date of earliest event reported): August 8, 2018

FRESHPET, INC.
(EXACT NAME OF REGISTRANT AS SPECIFIED IN CHARTER)

Delaware
(State or other jurisdiction
of incorporation)

001-36729
(Commission
File Number)

20-1884894
(IRS Employer
Identification No.)

400 Plaza Drive, 1st Floor
Secaucus, New Jersey 07094
(Address of Principal Executive Offices, including Zip Code)

(201) 520-4000
(Registrant's telephone number, including area code)

Not Applicable
(Former name or former address, if changed since last report)

Check the appropriate box below if this Form 8-K filing is intended to simultaneously satisfy the filing obligation of the registrant under any of the following provisions:

- Written communications pursuant to Rule 425 under the Securities Act (17 CFR 230.425)
- Soliciting material pursuant to Rule 14a-12 under the Exchange Act (17 CFR 240.14a-12)
- Pre-commencement communications pursuant to Rule 14d-2(b) under the Exchange Act (17 CFR 240.14d-2(b))
- Pre-commencement communications pursuant to Rule 13e-4(c) under the Exchange Act (17 CFR 240.13e-4(c))

Indicate by check mark whether the registrant is an emerging growth company as defined in Rule 405 of the Securities Act of 1933 (§ 230.405 of this chapter) or Rule 12b-2 of the Securities Exchange Act of 1934 (§ 240.12b-2 of this chapter).

Emerging growth company

If an emerging growth company, indicate by check mark if the registrant has elected not to use the extended transition period for complying with any new or revised financial accounting standards provided pursuant to Section 13(a) of the Exchange Act.

Item 7.01. Regulation FD Disclosure.

On August 8, 2018, Freshpet, Inc. (“Freshpet”) announced the planned expansion of its manufacturing facility at its campus in Hanover Township, Northampton County, Pennsylvania. Freshpet published to the investor relations section of its website a presentation used by members of Freshpet’s management team in meetings with analysts and stockholders. A copy of the presentation is attached hereto as Exhibit 99.1 and is incorporated herein by reference. A copy of the press release announcing the planned expansion is attached hereto as Exhibit 99.2 and is incorporated herein by reference.

The information furnished with this Item 7.01, including Exhibit 99.1 and Exhibit 99.2, shall not be deemed “filed” for purposes of Section 18 of the Securities Exchange Act of 1934, as amended (the “Exchange Act”), or incorporated by reference into any other filing under the Securities Act of 1933, as amended, or the Exchange Act, except as expressly set forth by specific reference in such a filing.

Freshpet uses the “Investors” section of its website (investors.freshpet.com) as a means of disclosing material non-public information and for complying with its disclosure obligations under Regulation FD.

Item 9.01. Financial Statements and Exhibits.

(d) Exhibits

Exhibit Number	Description
99.1	August Investors Presentation dated August 8, 2018
99.2	Press Release dated August 8, 2018

SIGNATURE

Pursuant to the requirements of the Securities Exchange Act of 1934, the registrant has duly caused this report to be signed on its behalf by the undersigned hereunto duly authorized.

FRESHPET, INC.

Date: August 8, 2018

By: /s/ Richard Kassar

Name: Richard Kassar

Title: Chief Financial Officer



Investor Day

August 8, 2018



bringing the power
of fresh food to pets



Katie Turner

ICR



Safe Harbor

Forward Looking Statements

This presentation contains “forward-looking” statements that involve risks, uncertainties and assumptions. If the risks or uncertainties ever materialize or the assumptions prove incorrect, the Company’s results may differ materially from those expressed or implied by such forward-looking statements. All statements other than statements of historical fact could be deemed forward-looking, including, but not limited to, the Company’s intentions, beliefs or current expectations concerning, among other things, the Company’s results of operations, financial condition, liquidity, prospects, growth, strategies and the industry in which we operate and any statements of assumptions underlying any of the foregoing. These statements are based on estimates and information available to us at the time of this presentation and are not guarantees of future performance.

These forward-looking statements are based on certain assumptions and are subject to risks and uncertainties, including those described in the “Risk Factors” section and elsewhere in the preliminary prospectus for this offering. You should read the prospectus, including the Risk Factors set forth therein and the documents that the Company has filed as exhibits to the registration statement, of which the prospectus is a part, completely and with the understanding that if any such risks or uncertainties materialize or if any of the relevant assumptions prove incorrect, the Company’s actual results could differ materially from the results expressed or implied by these forward-looking statements. Except as required by law we assume no obligation to update these forward-looking statements publicly, or to update the reasons why actual results could differ materially from those anticipated in the forward-looking statements, even if new information becomes available in the future.

Non-GAAP Disclosure

This presentation contains certain non-GAAP financial measures such as EBITDA and adjusted EBITDA among others. While the company believes these non-GAAP financial measures provide useful information for investors, the presentation of this information is not intended to be considered in isolation or as a substitute for the financial information presented in accordance with GAAP. Please refer to the Company’s earnings press releases for a reconciliation of non-GAAP financial measures to the most comparable measures prepared in accordance with GAAP.

Agenda

- **Introductions:** Katie Turner, ICR
- **Freshpet Story:** Scott Morris, Co-founder and COO
- **Feed the Growth:** Billy Cyr, CEO
- **Current Kitchens Capabilities:** Steve Weise, EVP
- **Kitchens 2.0 Objectives:** Billy Cyr, CEO
- **Kitchens 2.0 Plan:** Michael Hieger, SVP of Manufacturing Operations
- **Financials:** Dick Kassar, CFO, and Ivan Garcia, VP of Finance
- **Summary:** Billy Cyr, CEO
- **Q&A**
- **Tour**
- **Lunch and Additional Q&A**

Overview

- Strong progress over the past 18 months
- Growing share in the big, growing pet food market
- Significant upside potential ahead as HH penetration is low and favorable macro-trends
- Significant scale benefits
- Unique business model with significant competitive insulation

26 Billion Dollar Market with Strong Consumer Fundamentals

Pet Penetration

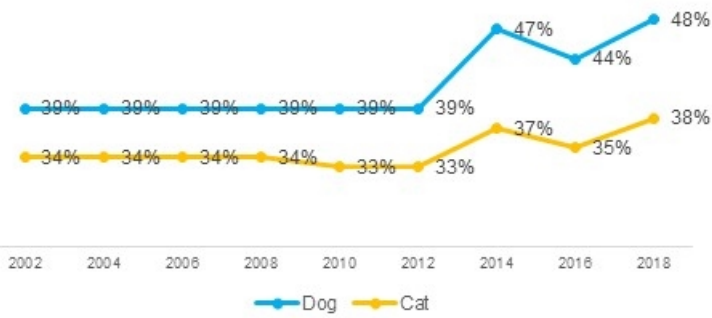

Size of Dog (%)

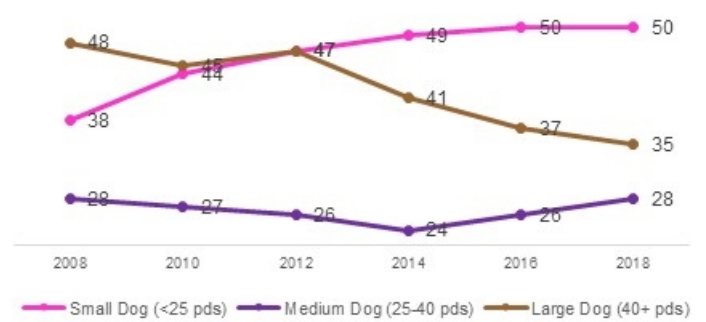

Pet Parent Demographics

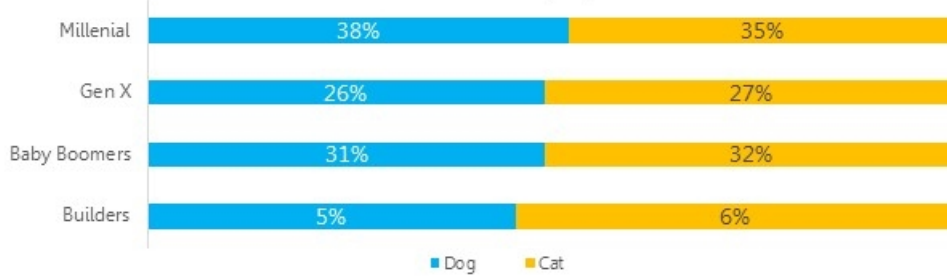

Scott Morris

Co-Founder & COO



Fresh food is
good food.





How are we
different?





**A new ideology to
make good simple
food for pets**



Our Purpose:

To transform the way we nourish our pets with fresh healthy food made in a way that's best for pets, people, and the planet.

We start with FRESH ingredients & finish with FRESH food.



No preservatives, no additives...only the WHOLE NURISHMENT pets need.

Our commitment



We are pet owners and we believed we could change the industry

- We realized that pets should be eating better than kibbles or cans, They should have fresh food like us with simple, less processed ingredients you can pronounce
- We worked with pet and human food experts to develop new ways to make fresh, healthy food for pets
- Our fresh food is good for weeks, not years and months like dry and wet pet foods

We make our food in our kitchens and operate it like a human food facility

- We built our own kitchens so we could make good food instead of having someone else do it for us
- We run our kitchens as though we are making food for humans because pets are part of our family
- We work with local farmers to get fresh ingredients daily and are picky about where they come from

We are honored to be one of the fastest growing pet food companies and doing things the right way

- We bought our own refrigerators to keep our food fresh in the pet aisle
- We are proud our food is different. We are even prouder about all the good things our food has done for dogs and cats
- Last year we fed over 2MM happy, healthy pets & we are humbled that they like us as much as we love them



The First company to
make real food for pets



How you do it is as important as what you do

At Freshpet, we have a single-minded mission -- to bring the power of real, fresh food to our dogs and cats.

And, we're committed to doing so in ways that are good for our pets, for people and for the planet.



pets.

The power of fresh
natural & simple foods
that are Less
processed
Acts of kindness



people.

Our team
Our partners
Our families



planet.

Efficient conservation
Renewable energy
Sustainable practices
Carbon footprint offset



our commitment to the environment



landfill free



powered
by wind



carbon
emissions offset

25,000+ trees planted

Commitment to our People & Family



Commitment to our **Retailer Partners**



Category Consumers

24% of shoppers were
NEW for retailer

Shortest purchase
cycle in the pet aisle!!

71% Repeat rates

40% Larger basket and
High % of fresh items

Freshpet draws most
coveted consumer demos
into pet aisle

Business

Category leading
growth rates +25%
CAGR

TL pet aisle is growing
+2x faster when
Freshpet is present

Category leading
margins ~ 28%

Retail / Fridge network
development - click and
collect / store delivery

High double digit
investment growth in
marketing, resources and
infrastructure

Commitment to our Consumers -

Category leading palatability

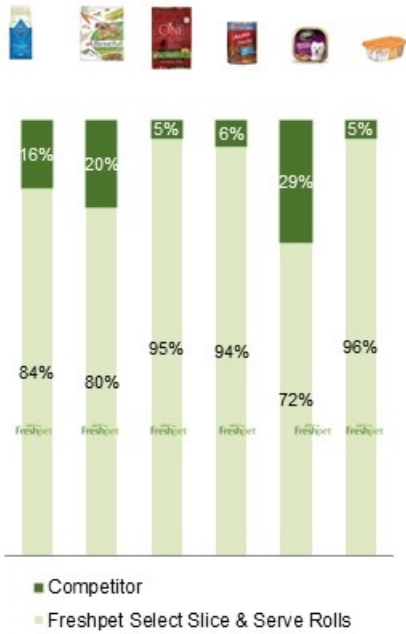

Source: Summit ridge kennels paired feeding study

76% of consumers report health difference

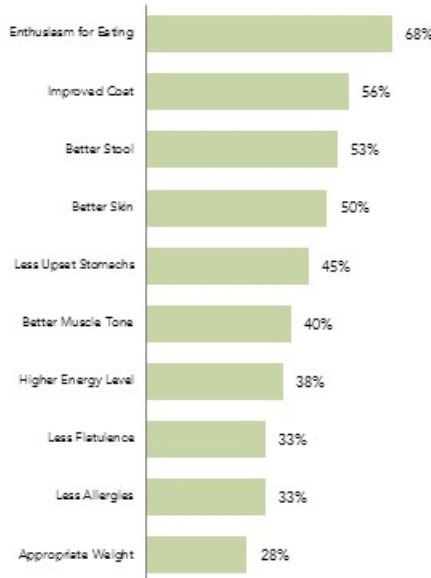

Source: Russell research attitude and usage study Freshpet n= 980

Category leading product satisfaction

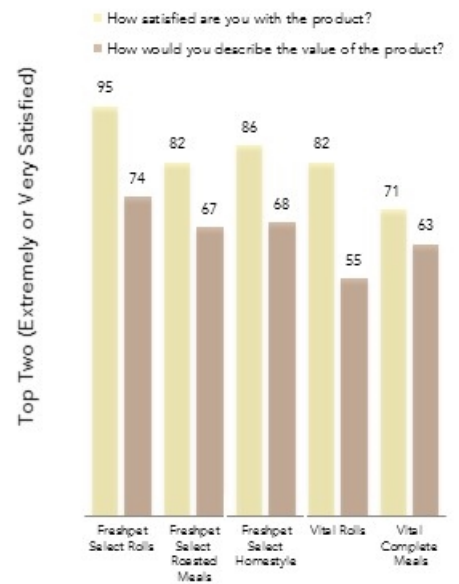

Source: Russell research attitude and usage study Freshpet n= 980
 Q22: Overall, how satisfied are you with each of the following products?
 Q23: How would you describe the value of each of the following products?

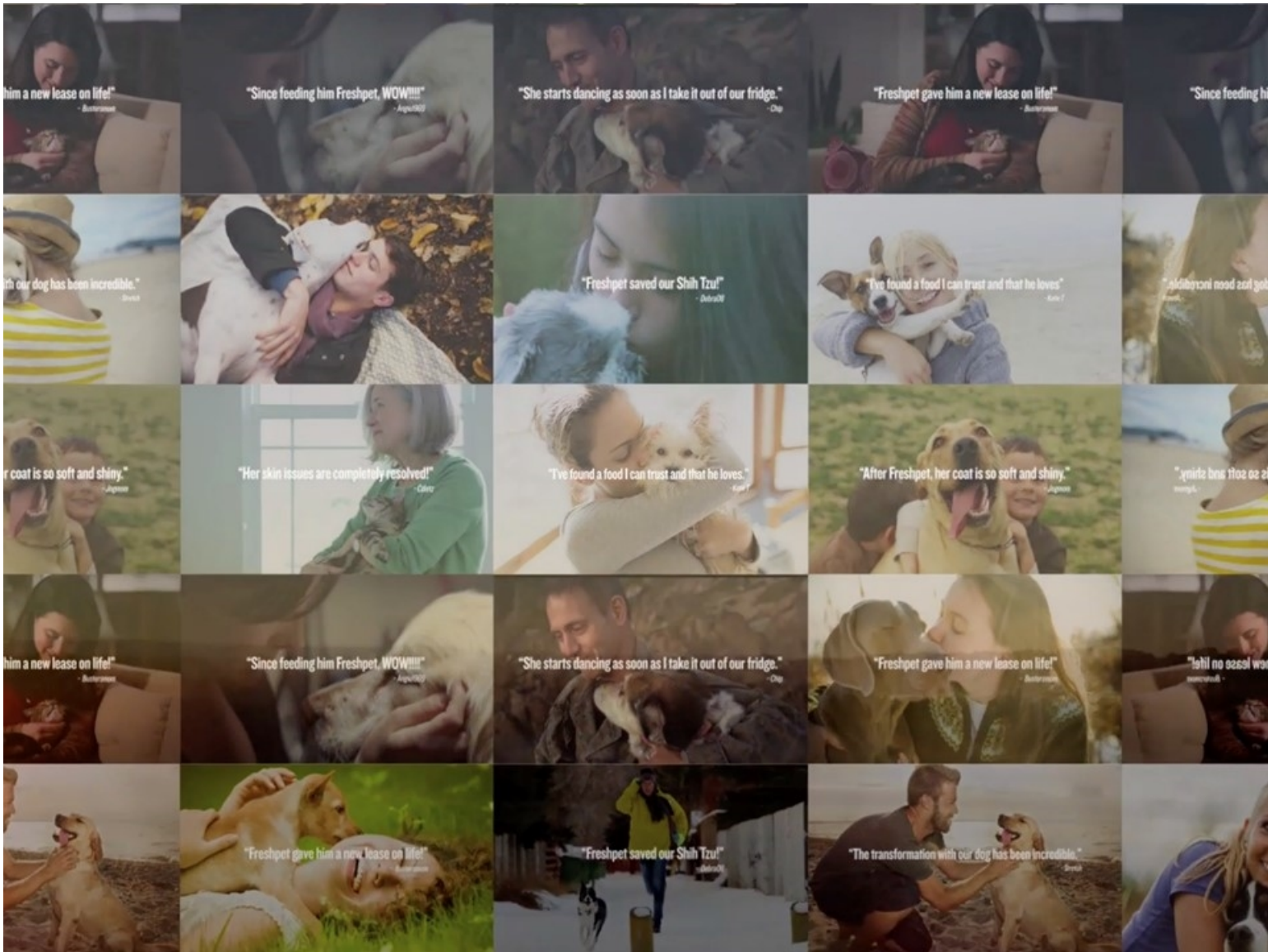



freshpet[®]
a fresh take on pet food

Billy Cyr

CEO





We fundamentally believe that
Freshpet has the potential to change
the way people feed their pets . . .
forever

A Potent Business Model

Differentiated

Innovative forms, technologies, and appearance



Manufacturing

Proprietary technology, processes, and infrastructure



High Brand Loyalty

Alignment with deep pet parent emotional motivations



Supply Chain

Only refrigerated pet food network in North America



Technical Knowledge

Production Scale

Product Performance

Freshpet Franchise

Distribution Scale

Brand Equity

Fridge Placements

Freshpet Fridge

Branded, company-owned real estate



Walmart

Retailer Partners

Delivers benefits in traffic, frequency and retailer margins

petco

Kroger

WHOLE FOODS MARKET

TARGET



100 Day Review Conclusion: Significant Potential to Grow . . . but we have underinvested in marketing

Consumer Appeal & Marketing Model



- High repeat & brand passion
- Low awareness
- Low Penetration
- Strong marketing model
- Outstanding message

Customer Support for Distribution



- Extensive network & scale
- Established & broad product portfolio
- Highly motivating retailer metrics
- Established sales & marketing team
- Significant white space

Operations Capabilities & Opportunities



- Expansion complete
- New lines running at parity
- Major investment in technical capability
- Strong focus on quality
- Significant capacity to support growth

Longer Term Potential = \$300 Million in Net Sales as soon as 2020



In 2017, We Launched Our New Strategy . . .

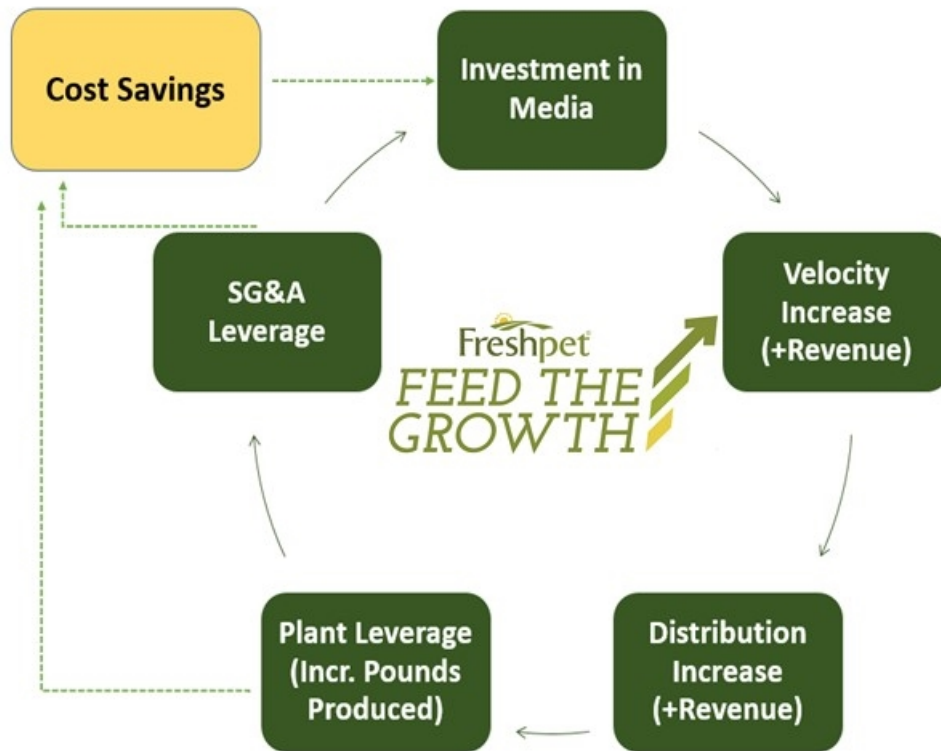

Growth Goal: \$300 Million Net Sales as Soon as 2020

Future Economic Model

	FY 2016	FY 2020
Growth Rate	15%	15-20%
Stores	16,609	23,000
Adj. Gross Margin	50.9%	53.9%
Adj. EBITDA Margin	13%	20+%
Media Investment	~6% of sales	~9% of sales
Advertising Payback	1.5 yrs.	--
Free Cash Flow	-\$13.9M	~15% of sales*

*Before capacity expansion for sales beyond \$300 million

And the Growth Accelerated...

Nielsen Mega-Channel: XAOC + Pet + WFM Sales Growth

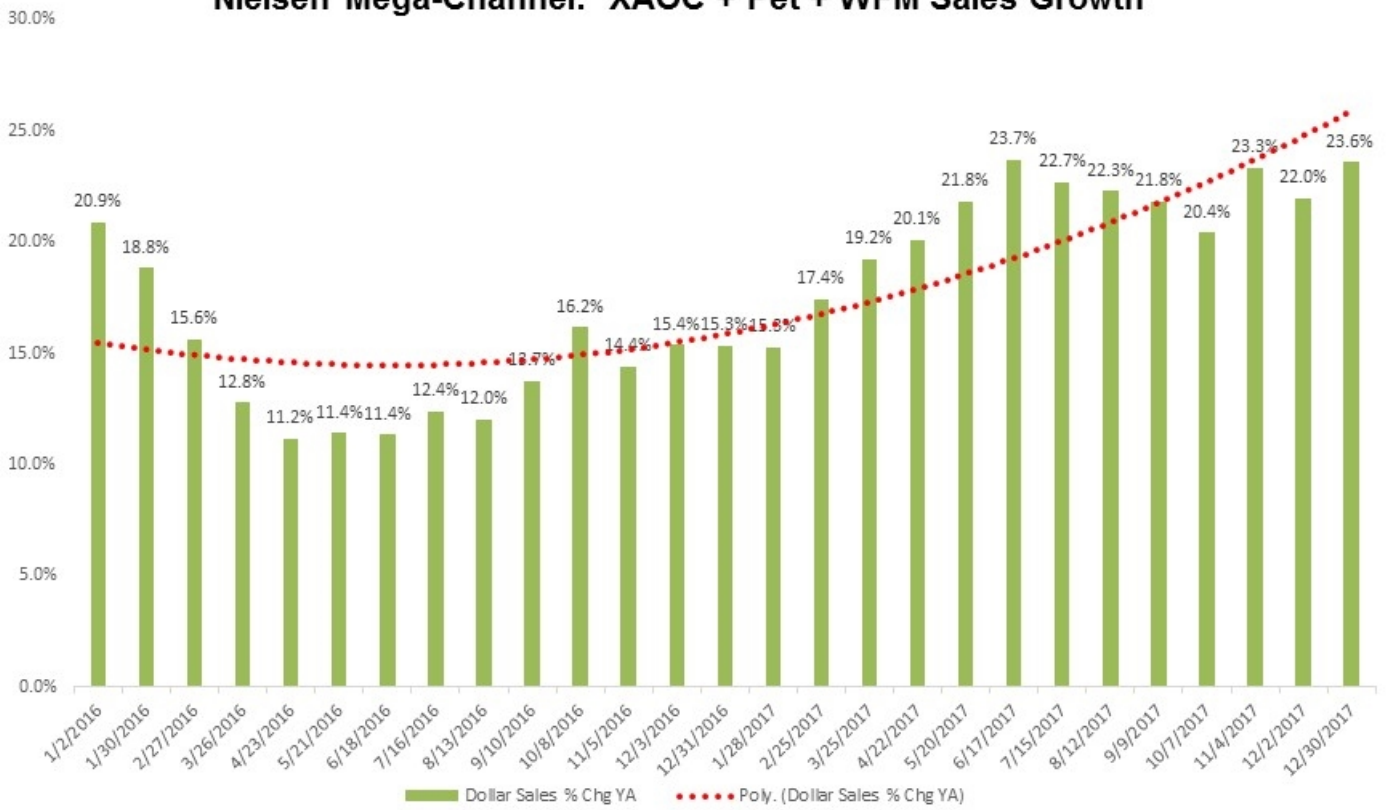

Increased Awareness & Penetration

Awareness

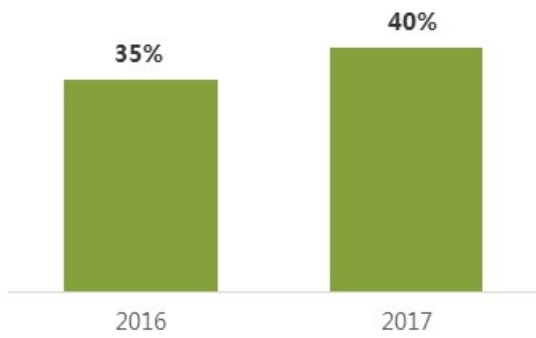

Penetration

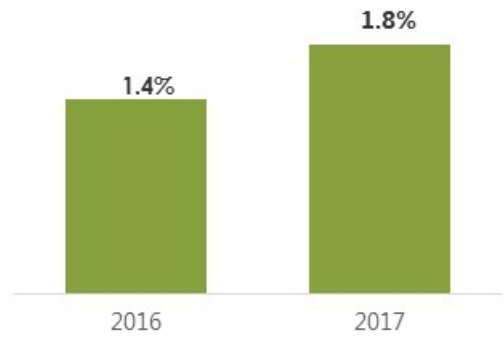

Buying Rate

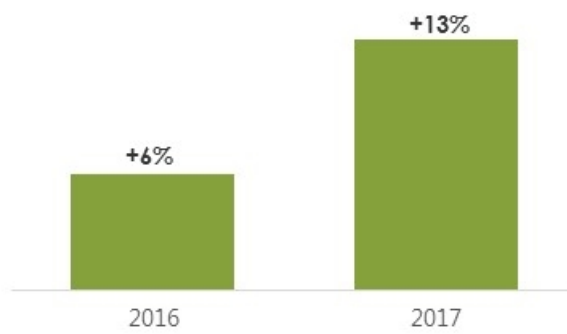

But Still Well Below Our Competitors....

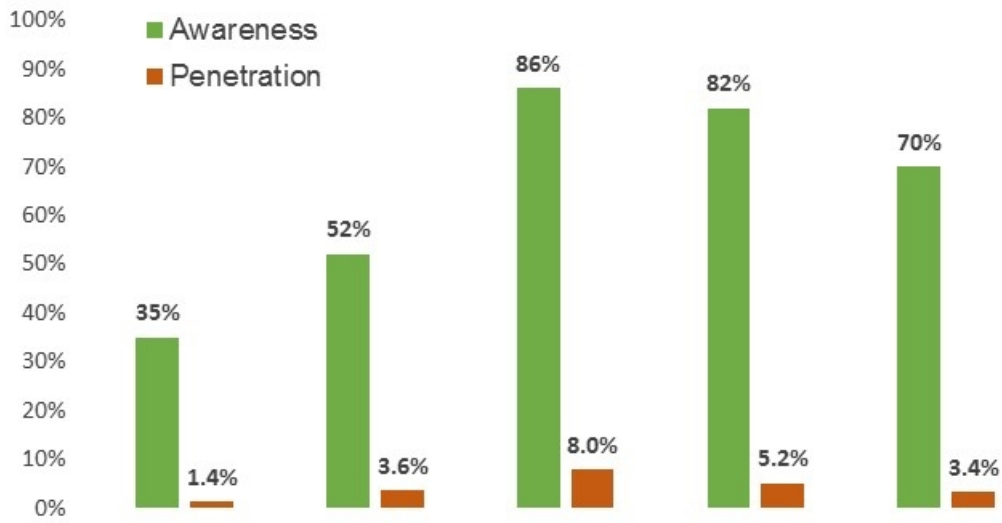

	Freshpet	RachelRay	Blue Buffalo	Purina ONE	Cesar
Awareness (Aided)	35%	52%	86%	82%	70%
Penetration	1.4%	3.6% (dry)	~8% (est)	5.2% (dry)	3.4% (wet)

Strong Velocity Growth...



Which Helped Freshpet Grow into its Scale in 2017...

100 bps reduction

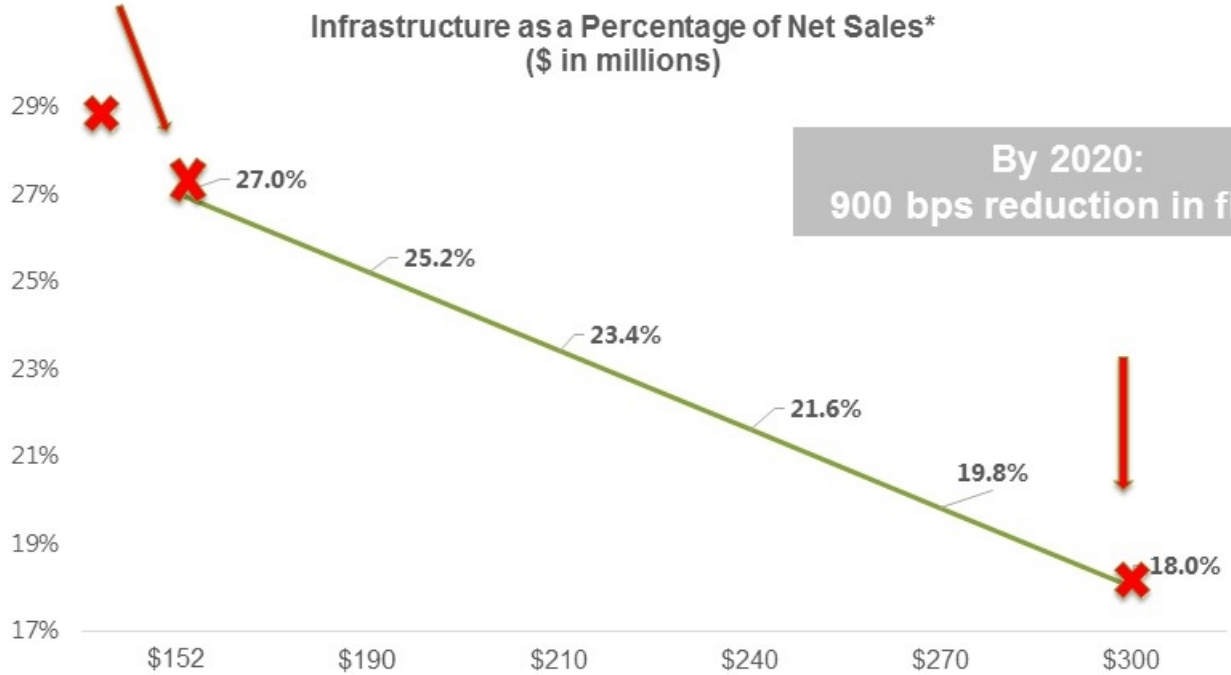

*Leverage adjusted to projected inflationary growth of infrastructure



**YEAR II: Bigger and
Faster**

In 2018, We Are Accelerating Fresh Growth...

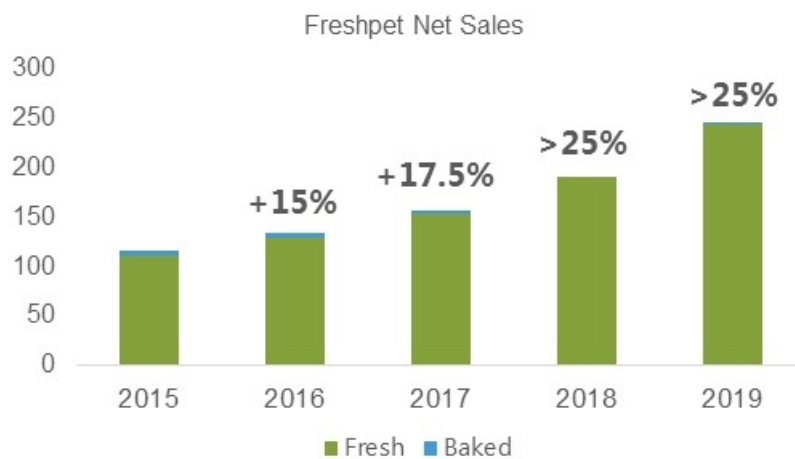

2018 Fresh-only sales guidance: +26%

2018 Guidance

	2017	2018	% Change
Net Sales	\$152.4	>\$190	25+%
Adjusted EBITDA	\$17.6	>\$20	14+%



Doubling Down On...

Media: 60% increase for the second year in a row

- Each quarter will increase vs. YA
- 70/30 first half vs. second half spending

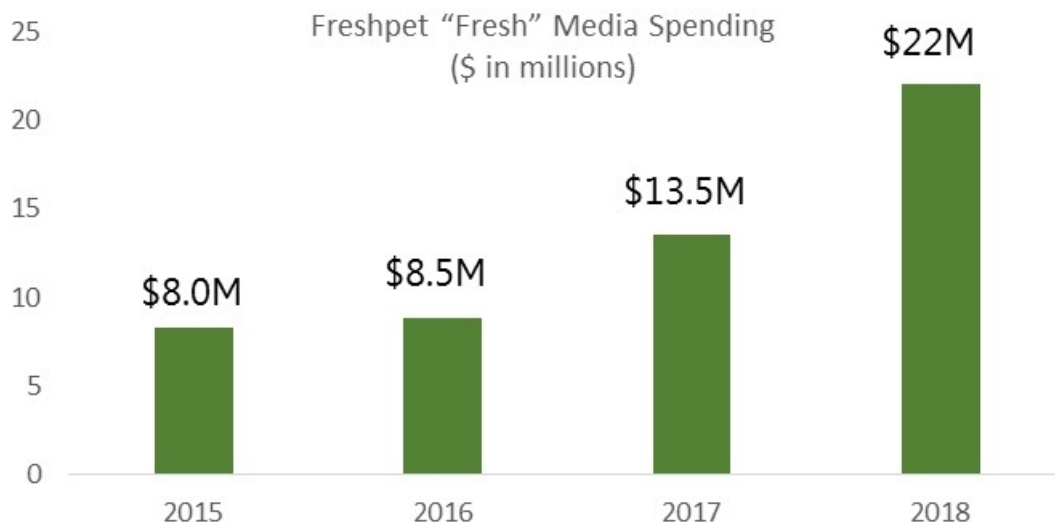

Doubling Down On...

Velocity drivers:
Upgraded fridges



Before



After

Focused innovation

Small Dog



Premiumization & Added Variety



Select Roasted Meals
Grain Free



Select Beef
Roasted Meals



Select Roasted Meals
Multi-Protein



And With Growth Potential in Fresh E-commerce

Strategy: Grow with winning players in fresh e-commerce



And the Growth Has Accelerated Again...

YTD '18 fresh consumption +27%

Nielsen Mega-Channel: XAOC + Pet + WFM Sales Growth

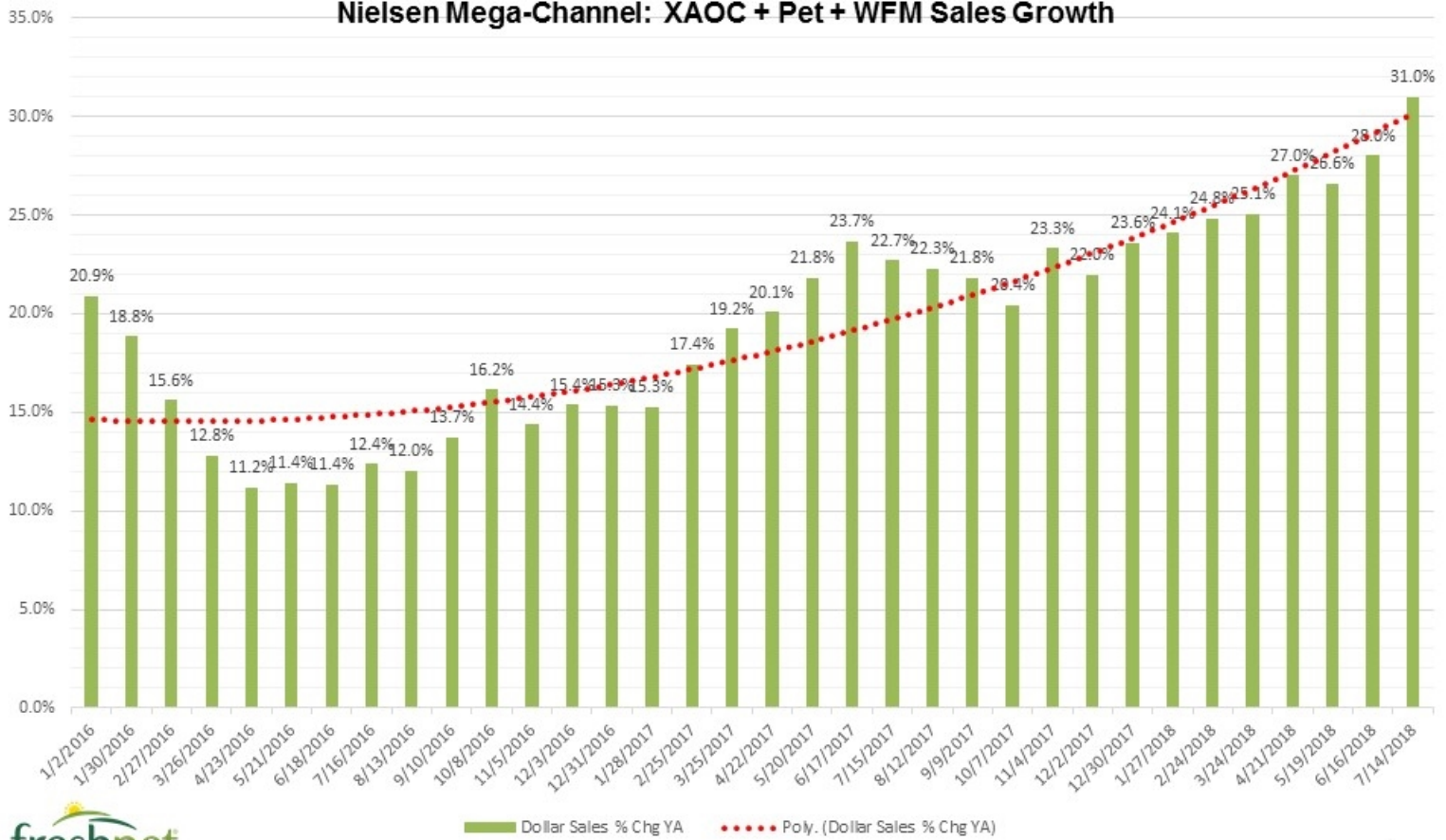

Growing 25 pts. faster than the category in all classes of trade ...

\$ % Chg YA – Week Ending 07/14/18

	Freshpet Total RFG		
	L4W	L13W	L52W
Total xAOC+Pet+WFM	31.0	28.9	24.8
Total US xAOC	32.5	30.4	27.4
Total US Food	37.0	33.9	31.3
Big Box Pet	25.2	24.2	15.7



Nielsen: Freshpet RFG \$ Latest 4 Week Data as of 7.14.18

Increased Penetration & Buying Rate

Total Freshpet Buying Rate, Penetration and Repeat Rate

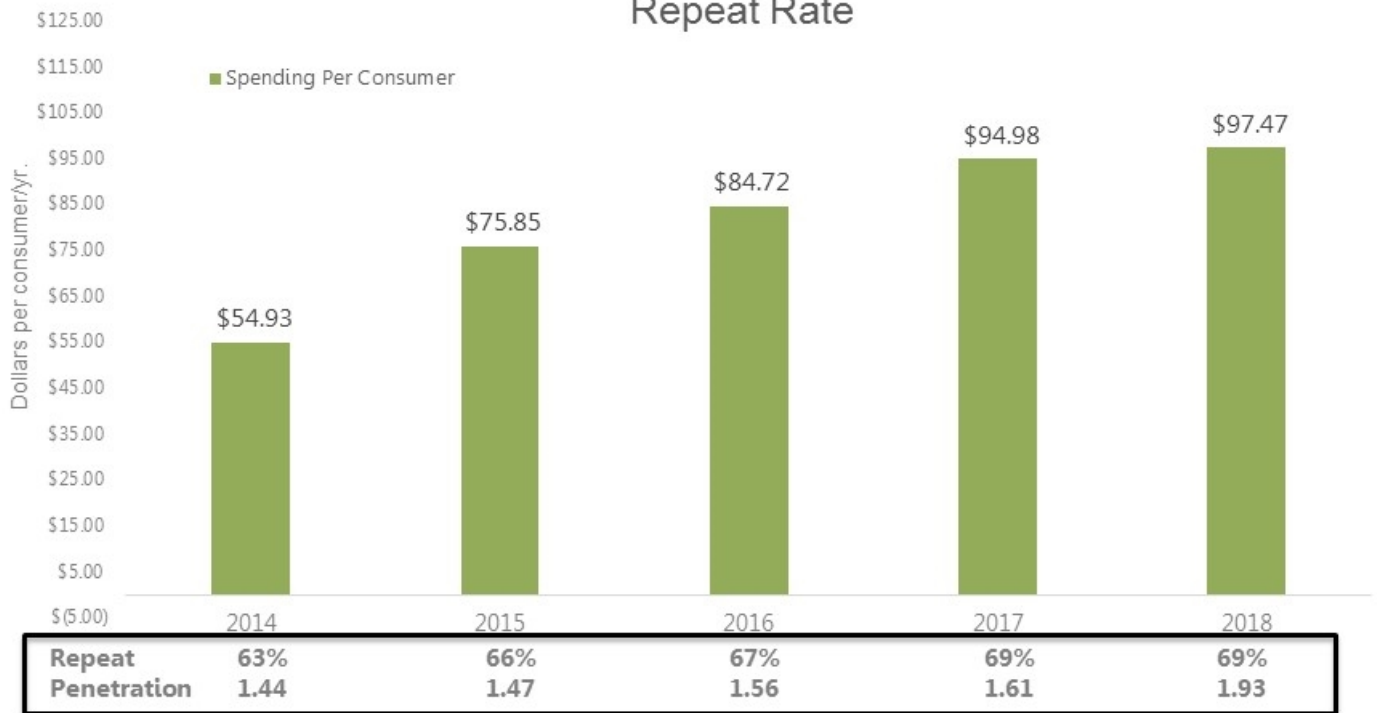

Source: TTL FP RFG, 52 weeks ending June 8/18, Nielsen HH Panel, Internal Buy Rate Calculation, Repeat NBD-Adj Nielsen HH Panel

Growth is Driven by Advertising that Drives Penetration

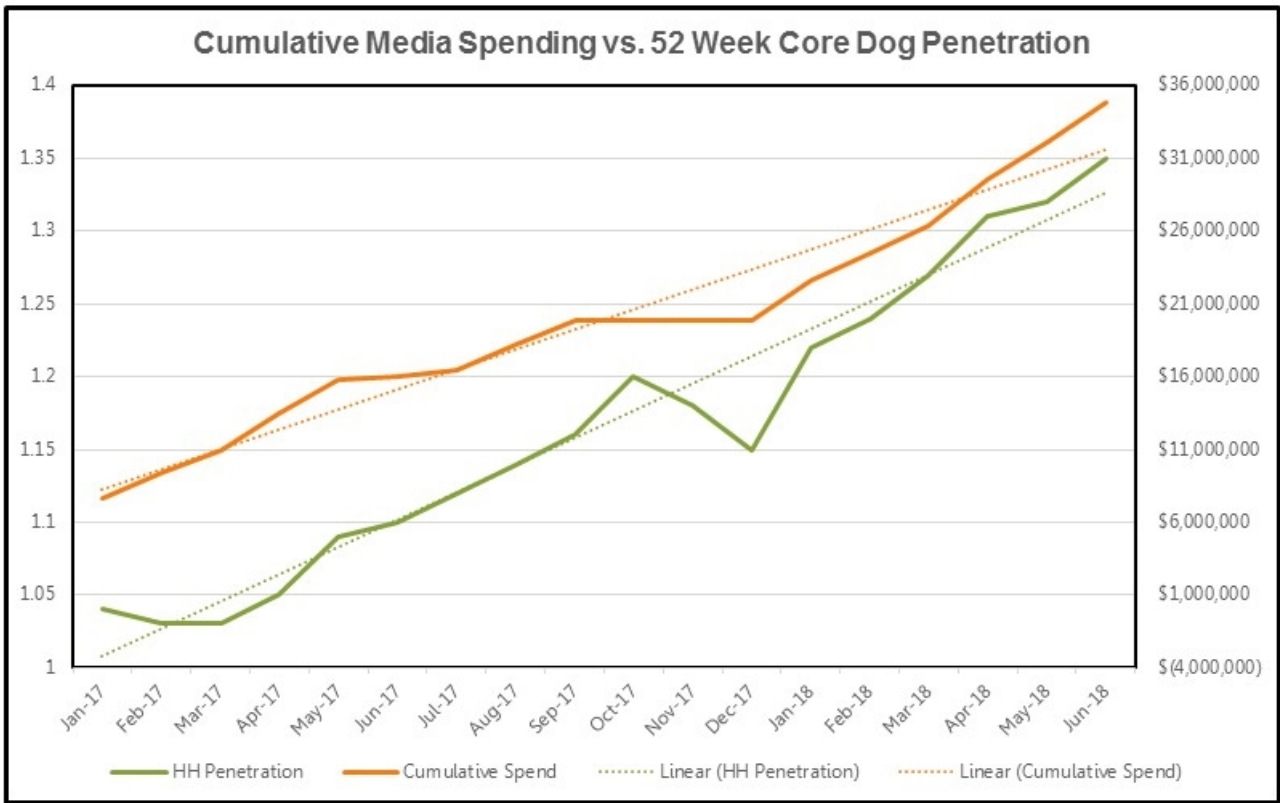

Nielsen HH Panel date for Freshpet Core Dog – Rolling 52 week penetration data



Adding New Buyers Who Behave Like Previous Buyers

New User Buying Rate: Freshpet Core Dog



Nielsen HH Panel date for Freshpet Core Dog – 52 week buying rate data for new users by year



Steady Distribution Growth & Accelerating Velocity

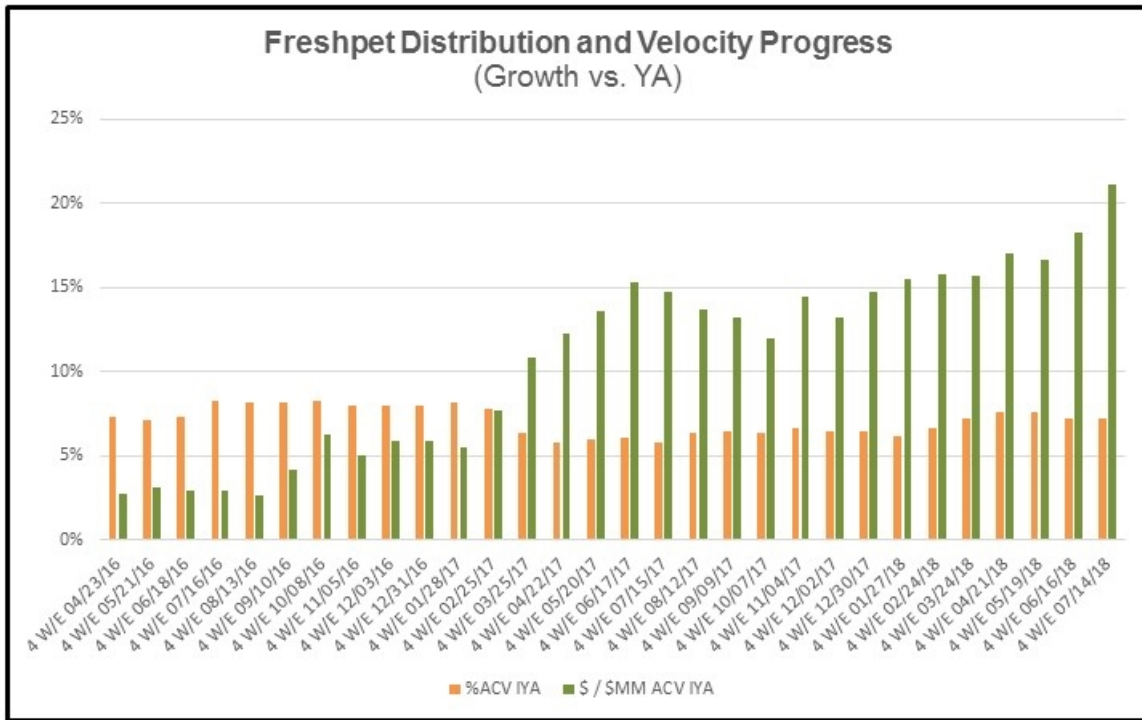

Nielsen Mega-Channel ACV and \$M/\$M ACV for 4 week periods 4/23/16 to 7/14/18



Growing Distribution Towards 50% ACV

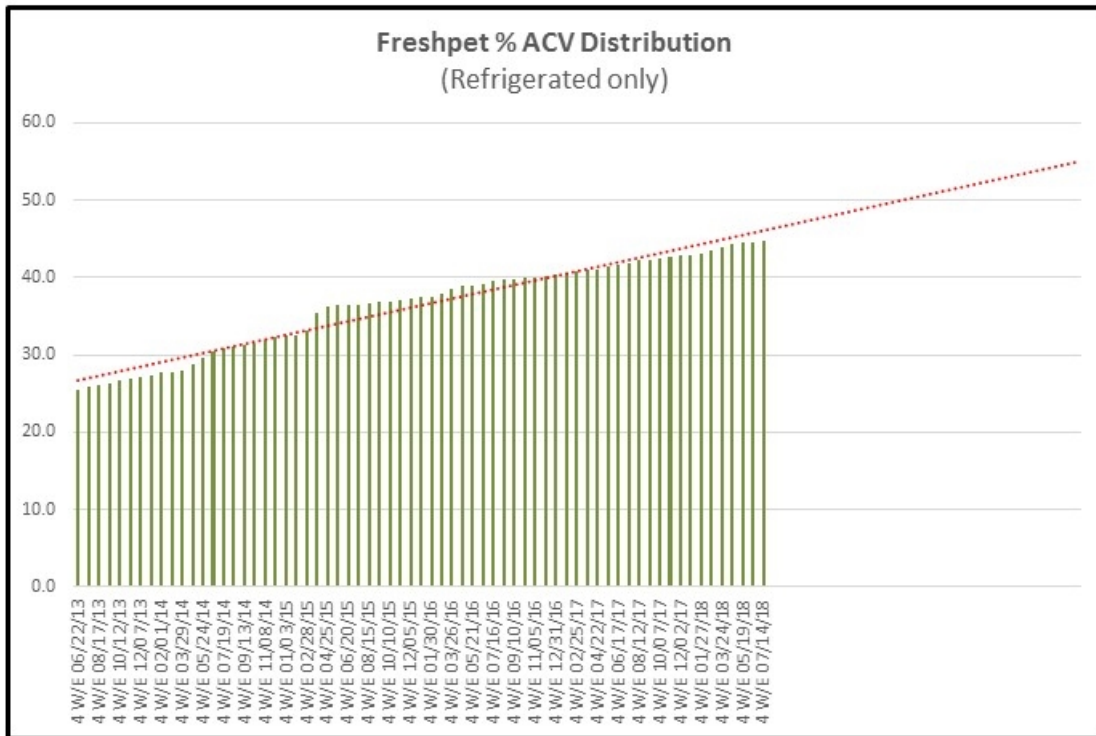

Nielsen Mega-Channel % ACV for 4 week periods 6/22/13 through 7/14/18

Freshpet grew into its scale in 2017 and again in the first half of 2018 and plans to deliver 9% incremental margin by 2020

Infrastructure Reduction as a Percentage of Net Sales* (\$ in millions)



*Leverage growth projected excluding media

Strong structural profitability improvement partially offset by commodities and 7 day production expansion

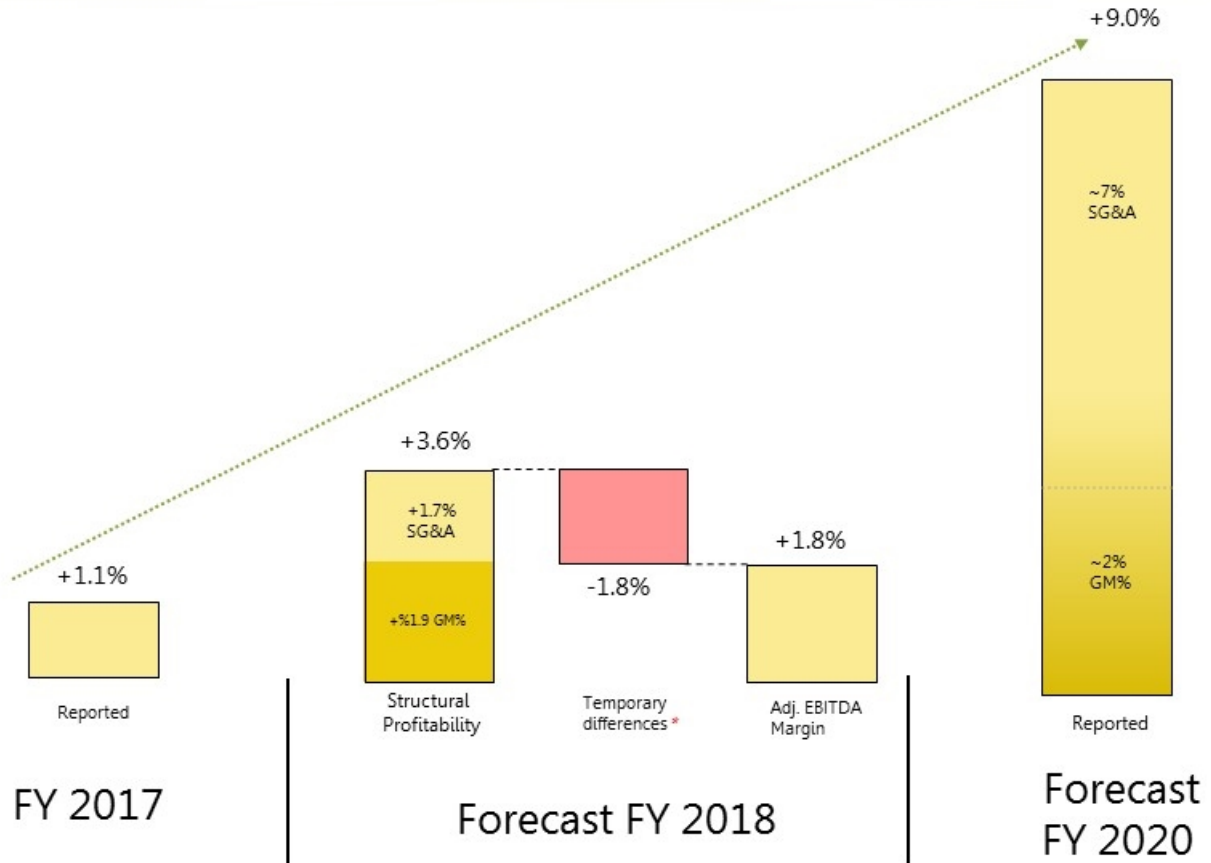

*Temporary differences in Forecast FY 2018 represent 130 basis points of raw material cost and 60 basis points related to unabsorbed labor from 7 day operation.

Benefits of Scale & Velocity

+900 bps

Fixed Cost Pick-Up

- Manuf. overhead absorption
- G&A overhead absorption

Logistics

- More cases per pallet
- More pallets per order/full trucks
- More straight pallets
- Ultimately, fewer miles per order

Retail Presence

- Lower % sales to service fridges
- Higher frequency retail coverage
- Higher visibility/more sophisticated fridges
- Fresher product
- Lower fridge capex per incremental \$ of sales

Advertising

- More continuous media
- Lower % of sales in media

Incremental gains

Path to 20% Adjusted EBITDA Margin

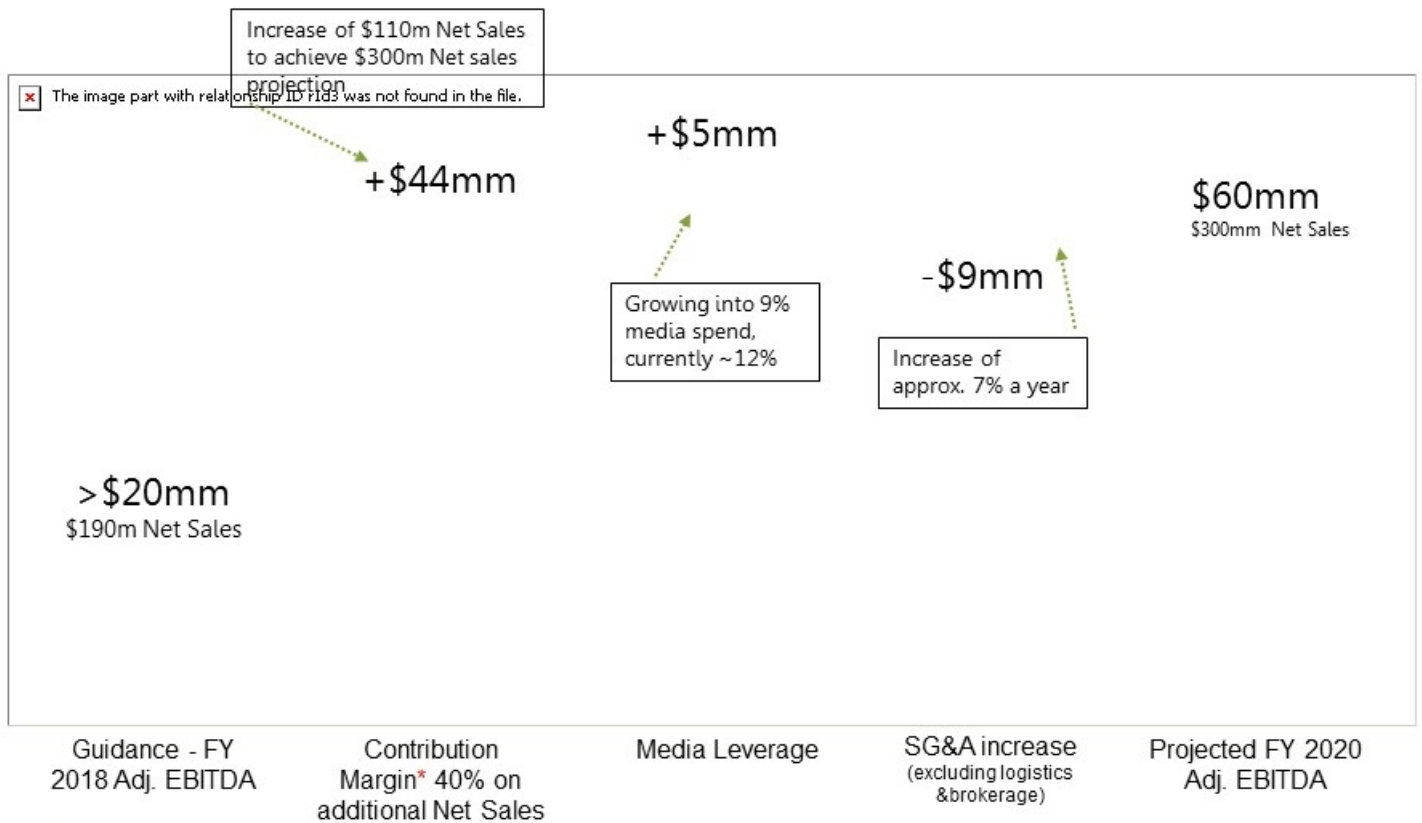

Contribution Margin* - Represents Adj. Gross Margin excluding Logistics and Brokerage cost.

Further Strengthening Our Barriers to Entry

Differentiated

Innovative forms, technologies, and appearance



Manufacturing

Proprietary technology, processes, and infrastructure



High Brand Loyalty

Alignment with deep pet parent emotional motivations



Supply Chain

Only refrigerated pet food network in North America



Technical Knowledge

Production Scale

Product Performance

Freshpet Franchise

Distribution Scale

Brand Equity

Fridge Placements

Freshpet Fridge

Branded, company-owned real estate



Walmart

Retailer Partners

Delivers benefits in traffic, frequency and retailer margins

petco

Kroger

WHOLE FOODS MARKET

TARGET



Just Scratching the Surface of HH Penetration Potential...

Prime Prospects

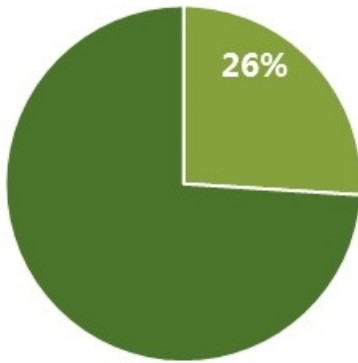

→ PP's with Positive Interest (53%) →

With Top 2 Box Purchase Interest in Freshpet Concept

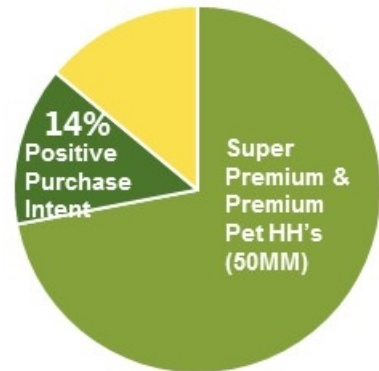

By 2025, there will be **7.5 million HH's** who have expressed top 2 box purchase interest in the Freshpet idea – and we have reached <2 million so far

At existing media efficiencies, we could create a business surpassing \$500 million by 2023....and still growing quickly

Freshpet Growth Potential

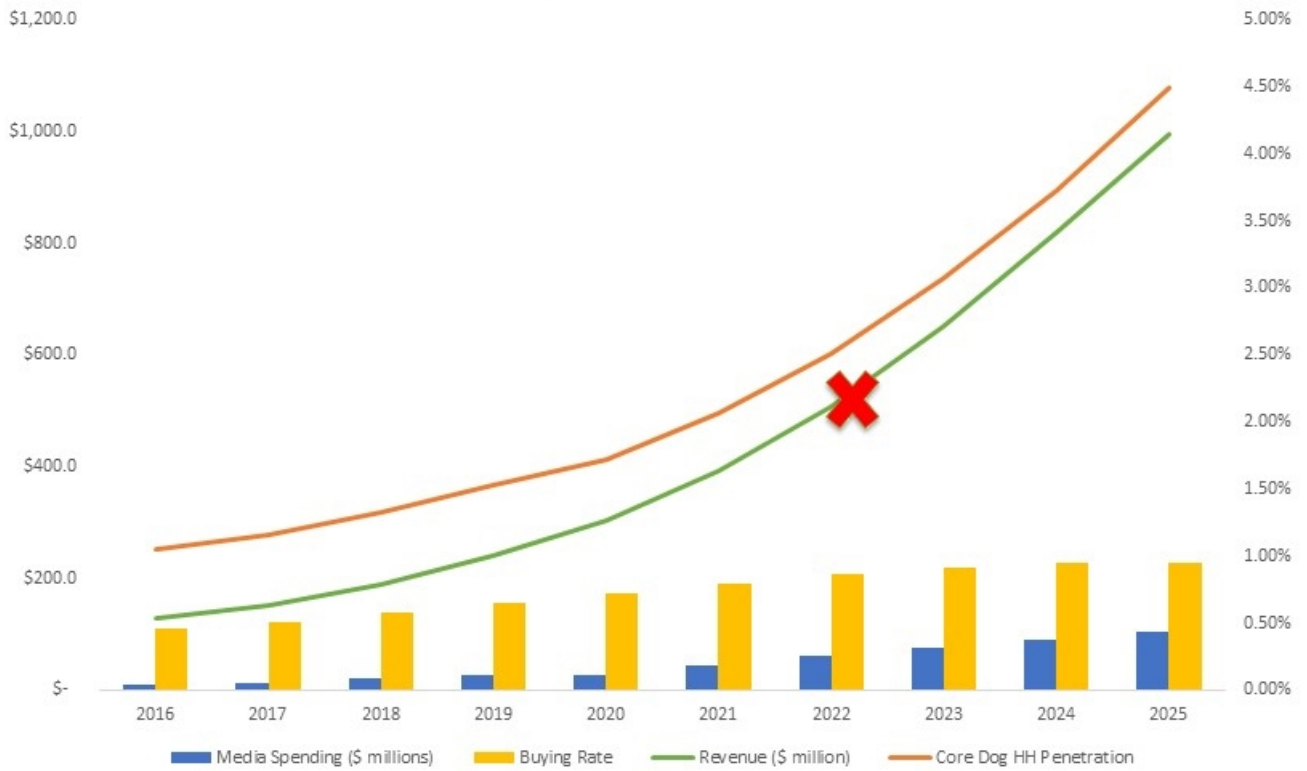

We expect international expansion to meaningfully impact Freshpet's growth in 2020 and beyond

Currently testing in:

TESCO

ASDA

HOOGVLIET



freshpet
REAL PET FOOD

Steve Weise

EVP of Manufacturing



Development of Freshpet Manufacturing Expertise



Quakertown

Kitchens

Improving Safety, Quality, Value, Customer Delight

2012: Original Kitchens Building Purchased

- Converted from dairy to pet food
- Capability to produce rolls and bags
- Capacity to support \$100-120 million
- Core team transferred from Quakertown
- Proprietary formulation, process and packaging
- Investment in sanitary design



2015-2016: Expanded Facility

- Designed to support a \$300+ million business on a 7 day week
- Upgraded technology/continued focus on sanitary design
- Maximized the build out on the existing site
- Prioritized product quality and capacity, not labor saving automation



Current Operations

- 4 lines: 2 bag and 2 rolls
- Currently operating any 3 lines 5 days per week 24 hours per day
- Transitioning one line to a 7 day operation on September 9th
- Ultimately we will staff all 4 lines 7 days per week



Summary of Existing Investment

- **Total capital invested to date:** \$75 million
 - Includes the cost benefit of buying and re-purposing the original building
 - Includes the construction costs typical of 2012 - 2015
- **Space constraints limit automation**
 - Next facility will require more space and more equipment to enable greater automation



Ready to Expand our Capacity & Expertise Again...



Quakertown

Kitchens

Kitchens
2.0

Improving Safety, Quality, Value, Customer Delight



Billy Cyr

CEO



Freshpet Kitchens 2.0 Objectives

- Expand capacity to support a \$500+ million business
- Drive improvements in quality, safety and cost
- Build organization capability to support future capacity expansions at a second, geographically-diverse site

Bethlehem: The Right Site for Kitchens 2.0

- Scale/Operating flexibility benefits > than freight savings opportunity
- Talented, local engineering team reduces technical risk
- Highly skilled local operating team reduces start-up and operating risk
- Opportunity to further develop expertise and talent pool before transferring it to a new site
- We can offset most “single site risk” via alternate methods

Freshpet Kitchens 2.0 Will Deliver

- ~\$540 million total capacity (\$200+ million increase) that pays for itself within 1.5 years of full capacity utilization
- Adjusted gross margin increase of 150 bps on the whole business
- Greater control of quality and enhanced safety
- Increased scale benefits in purchasing and shipping
- Greater innovation capabilities

Michael Hieger

SVP of Manufacturing



Increased Automation is the Key Enabler

Use automation to further improve:

- Quality
- Safety
- Cost



Creating 2nd Production Facility on Site

Total site: 15.3 acres

New 90,000 sq. ft. construction

Existing 50,000 sq. ft. innovation center and warehouse renovated to include production and R&D

Existing 100,000 sq. ft. production facility

Existing Facility

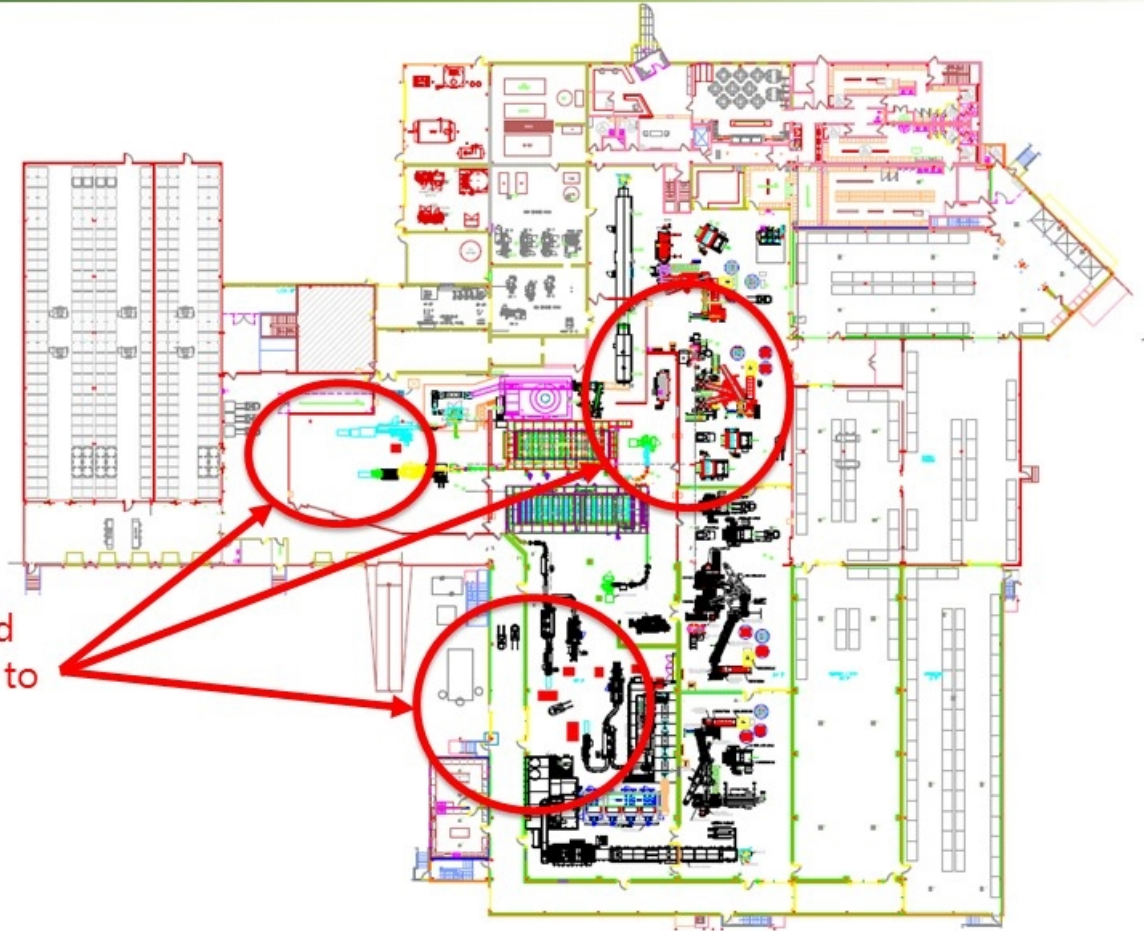

Space constrained areas limit ability to add automation

Kitchens 2.0 Includes:

- New, high speed bag line that drives margin improvement
- Incremental high capacity roll line that improves throughput
- Increased automation on raw material & ingredient handling and back-end
- Automated quality and safety enhancements
- Critical infrastructure: freezer, cooler, shipping and receiving docks, finished product storage, utilities

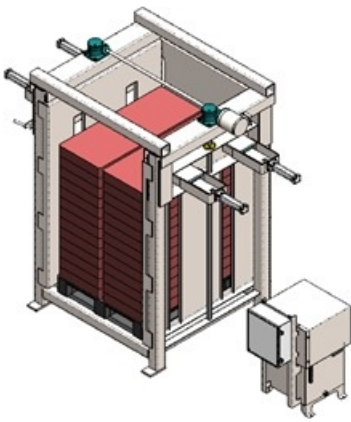

Palletizer Automation

Existing Facility



New Facility



Raw Material to Finished Product Flow

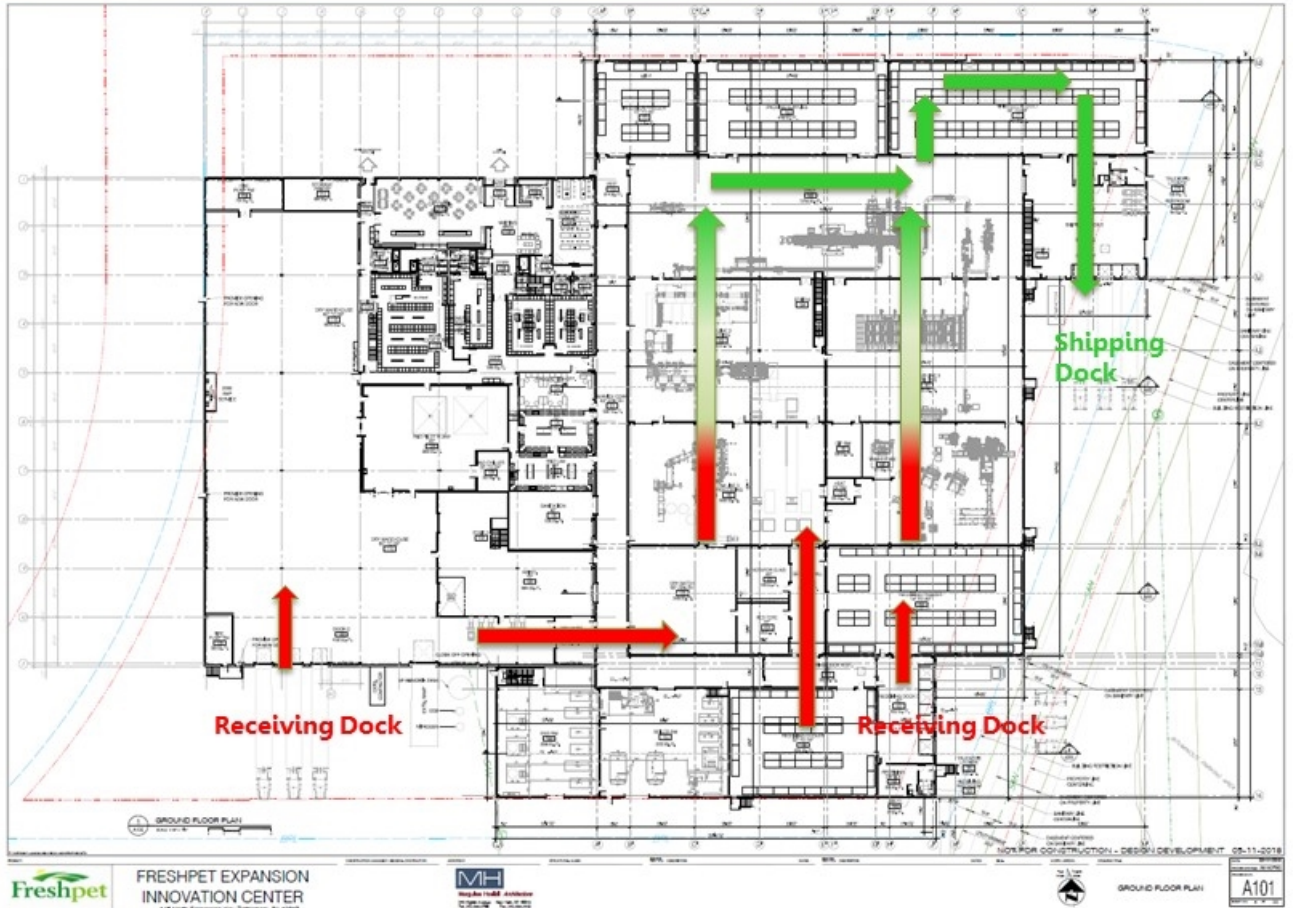

Risk Reduction Benefits of 2 Buildings & Labor & Inventory Benefit of a Single Site

Two Buildings:
Reduced risk of a catastrophic business interruption due to fire, wind or bacteria

Single Site: Trained experienced resources for start up and ramp up



Upgraded Technology:
Focus new facility on high volume sku's to drive margin improvement and

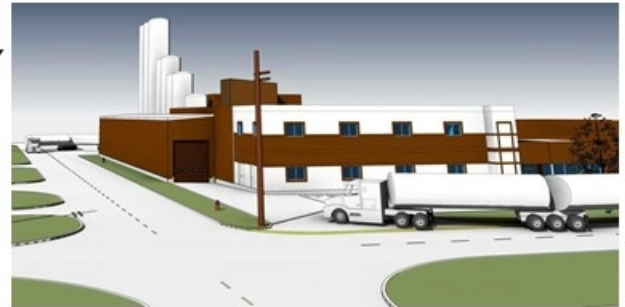

Single Site: Optimized production scheduling as we grow from \$300 - \$500 million

Continuing Commitment to the Environment

- ▶ 100% landfill free
- ▶ 100% wind energy
- ▶ Rain water will be collected and used for lawn and landscape irrigation



GOOD STEWARDS OF THE ENVIRONMENT

At Freshpet, we're always looking for ways to minimize our impact on the environment wherever we can. We're devoted to running our operations in a sustainable and efficient manner by utilizing 100% wind energy and minimizing waste and materials to become 100% landfill free at the Freshpet Kitchens. We're also reducing energy consumption with Smart Way Transport and energy-efficient fridges



Total Cost: ~\$100 million (+/- 5%)

Dick Kassar

CFO

&

Ivan Garcia

VP of Finance



Freshpet Kitchens 2.0 Investment

- Incremental volume will flow through at a 40% contribution rate
- At full capacity payback is less than two years.

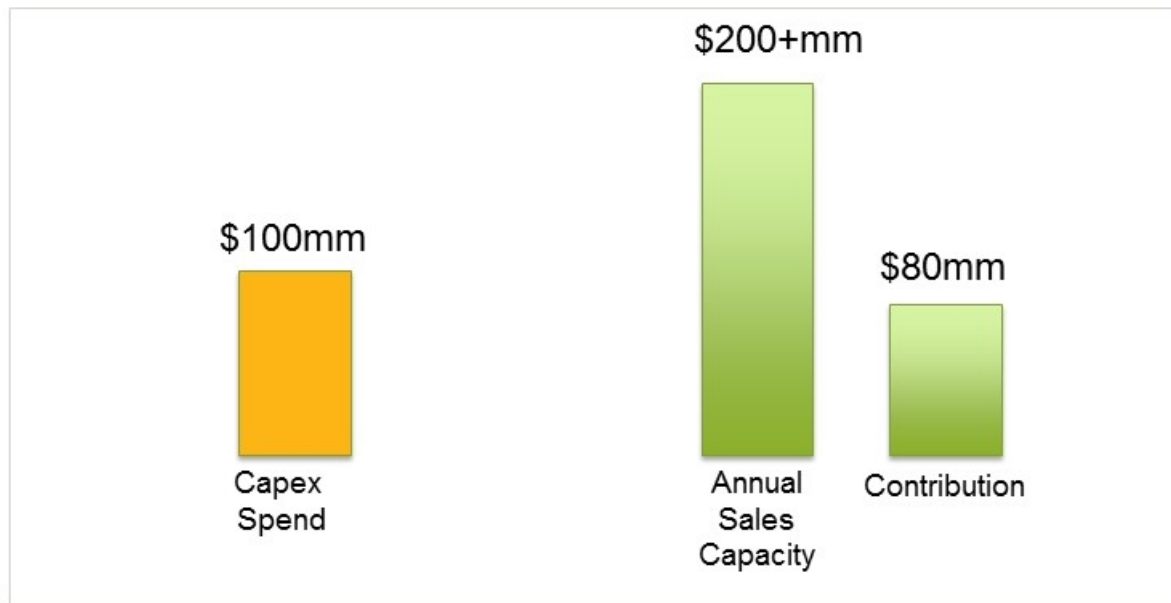

Freshpet Kitchens 2.0 Adjusted Gross Margin Growth

- Safety, quality, and productivity enhancements will improve adjusted gross margin by 100 basis points, with an additional 50 basis points due to scale

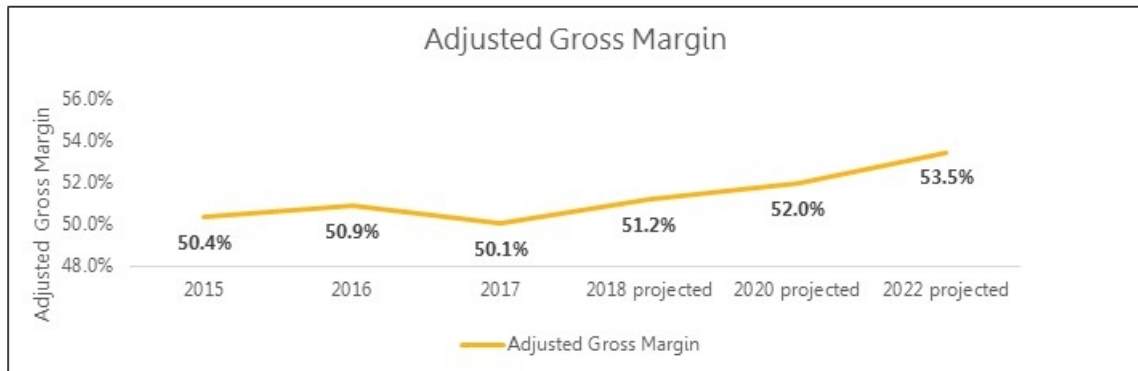

Freshpet Kitchens 2.0 Contribution to FCF

As we continue to leverage our infrastructure we expect to reap the benefits of scale with our Free Cash Flow increasing by 4%.

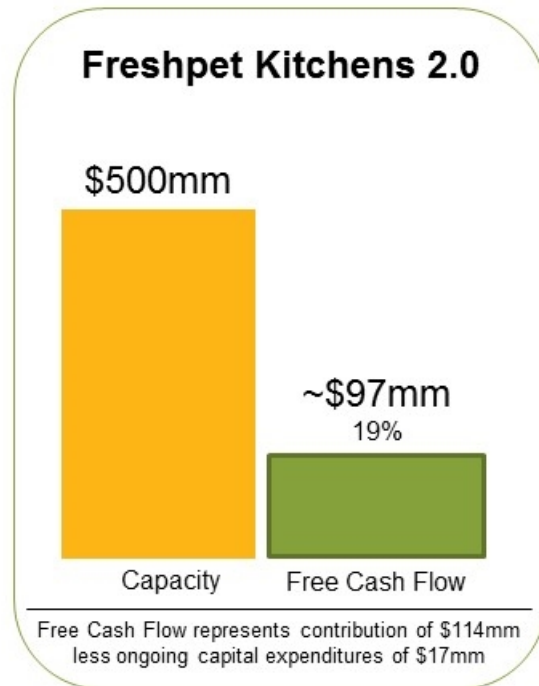
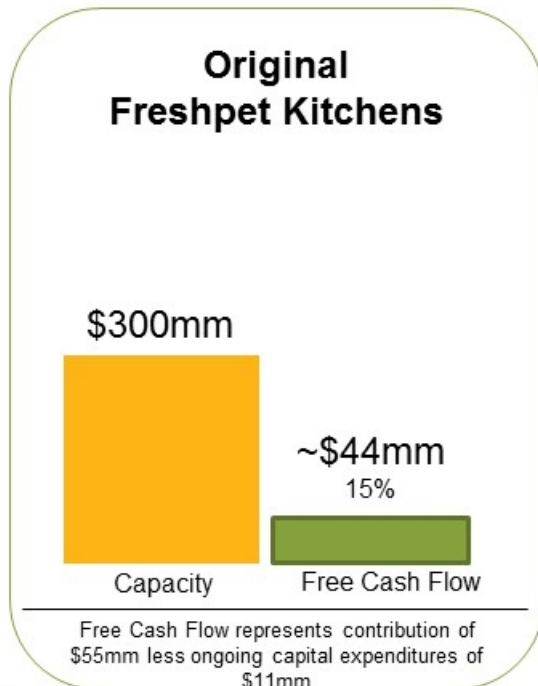

Freshpet Kitchens 2.0 Financing

- **Financing:** Replace our existing \$30 million credit line with a \$90 million line in Q4 18
- **Leverage:** Will not exceed 2.5x Adj. EBITDA

	FY 2018	FY 2019	FY 2020	FY 2021	FY 2022
Capex Spend	\$8mm	\$55mm	\$37mm	\$-	\$-
Max Debt Drawdown	\$-	\$60mm	\$55mm	\$50mm	\$-

Freshpet Kitchens 2.0 - Recap

- **Cost:** \$100mm plus or minus 5%
- **Financing:** Replace our existing \$30mm credit line with a \$90mm line in Q4 18
- **Leverage:** Will not exceed 2.5x Adj EBITDA
- **Pay Off:** We expect to pay off the credit line by 2022
- **Capacity:** Net Sales capacity increases \$200mm+ to \$500mm+
- **Payout:** At full capacity payout is less than 15 months



Billy Cyr

CEO



Timeline

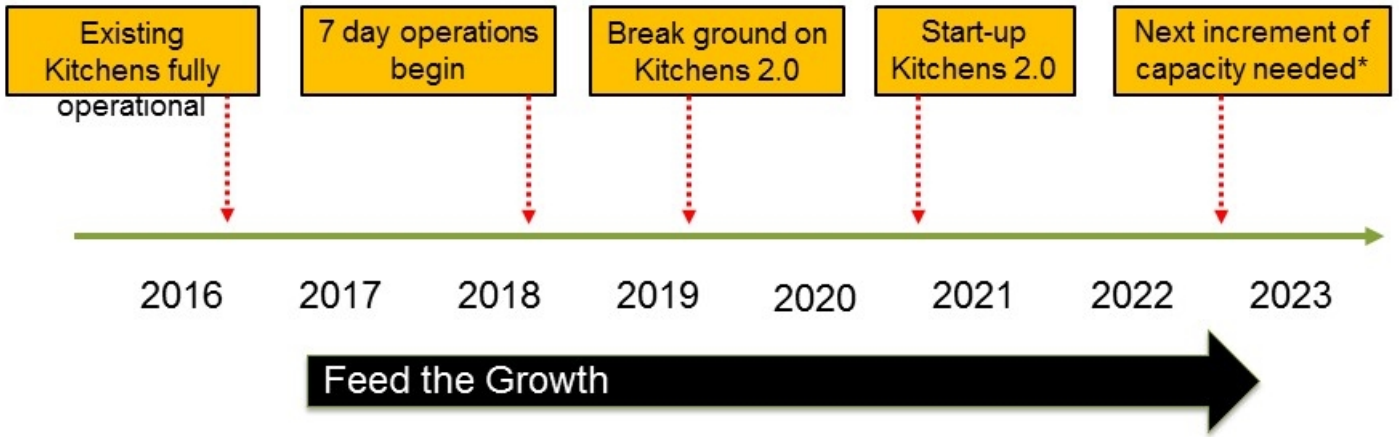



We believe that the Freshpet
business model is incredibly robust
and capable of enabling the
category-changing potential of the
Freshpet brand

Potential for Continued Growth Beyond 2020

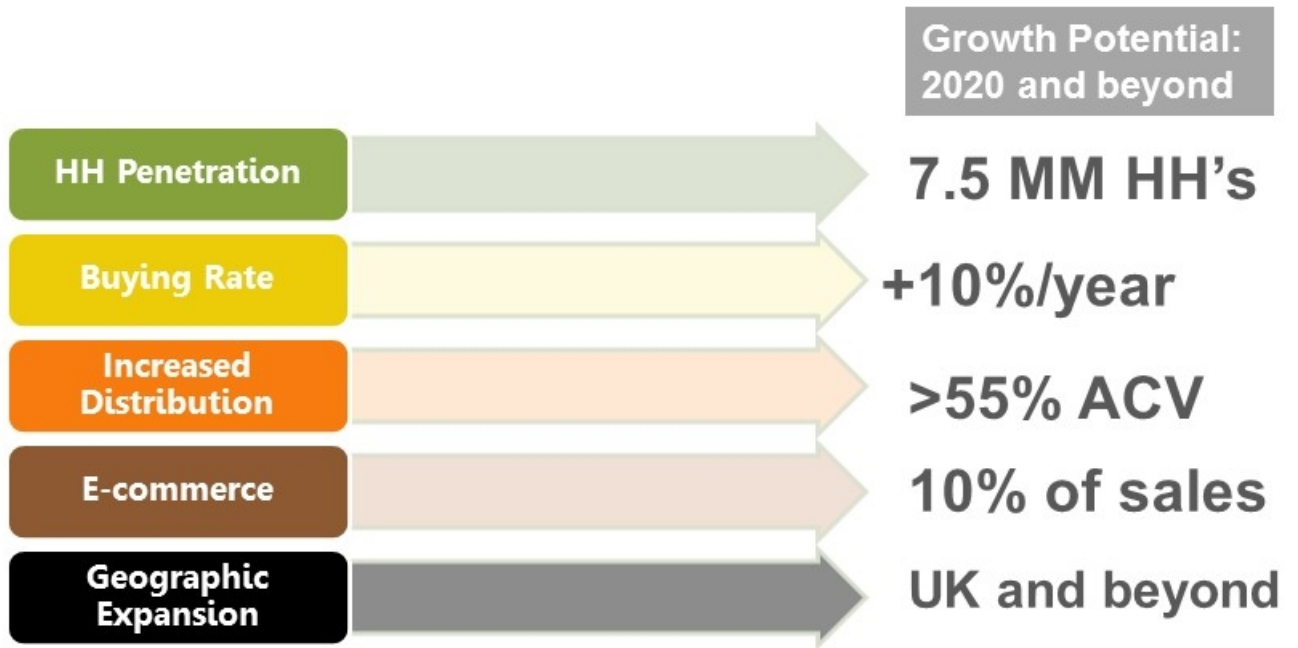

This page intentionally left blank.



Delighting Pet Parents, Pets, Shareholders & Employees...

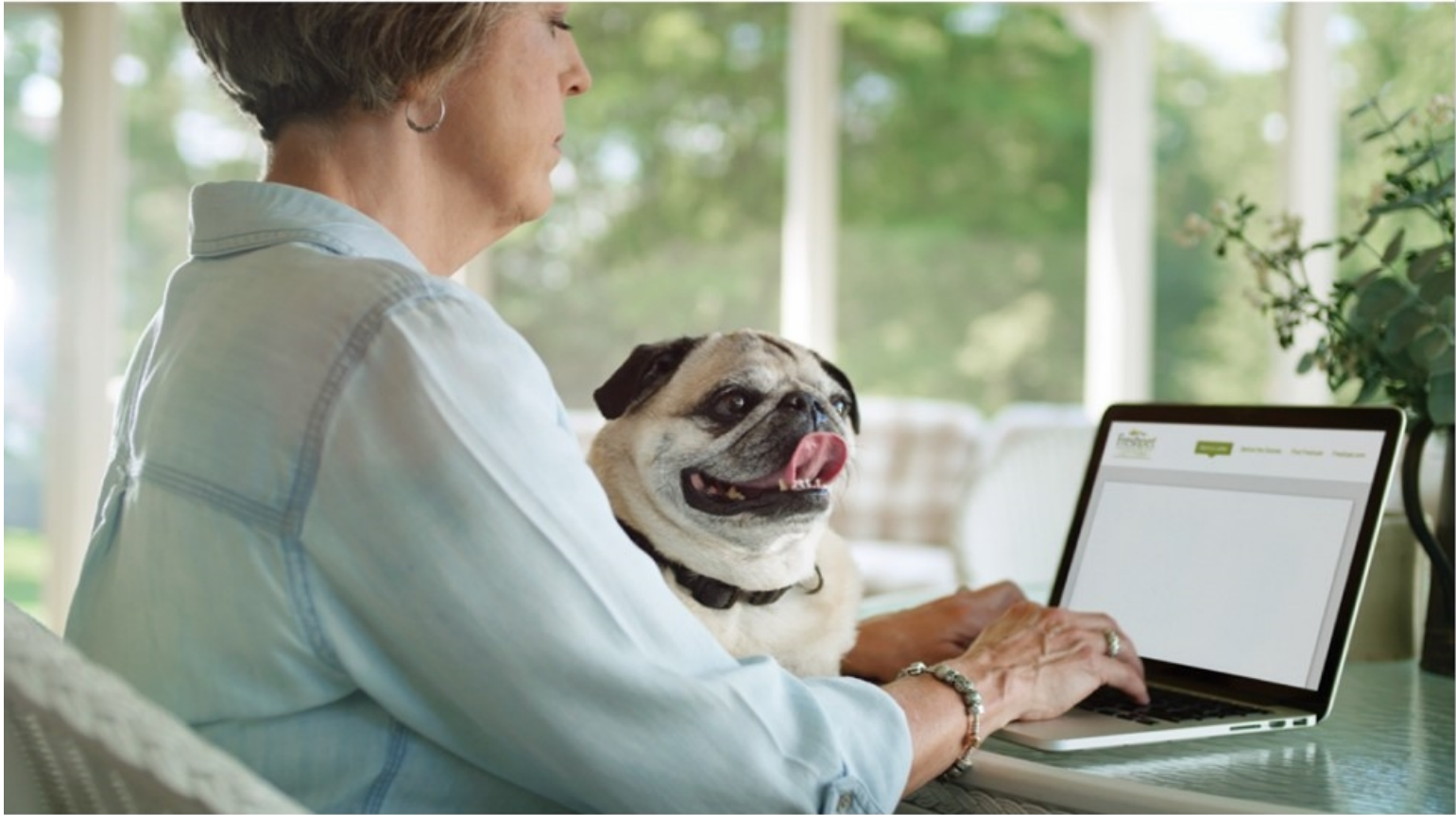

Delighting Pet Parents, Pets, Shareholders & Employees...

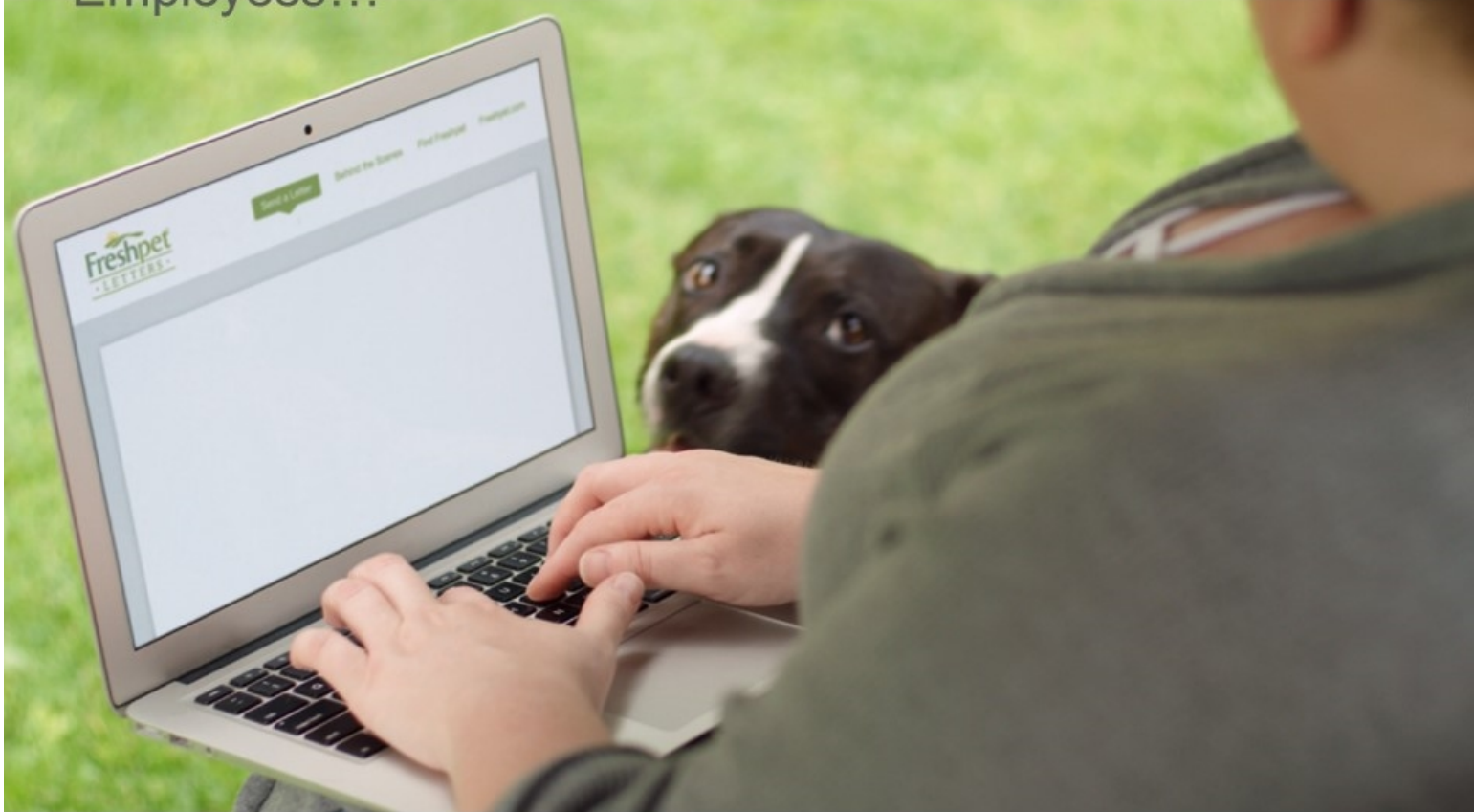





Freshpet, Inc. Announces Kitchens Expansion

Strategic Capital Investment to Support Freshpet's Growth in Net Sales to Over \$500 Million

SECAUCUS, N.J. – August 8, 2018 – Freshpet, Inc. (“Freshpet” or the “Company”) (NASDAQ: FRPT) today announced plans to expand its manufacturing capacity at its campus in Hanover Township, Northampton County, PA. The expansion includes the renovation of an existing 50,000 square foot building and a 90,000 square-foot addition. The \$100 million strategic capital investment is expected to support Freshpet’s growth in the United States, Canada and Europe by creating total capacity for approximately \$540 million in net sales from the facility. The facility “Freshpet Kitchens 2.0” will make greater use of automation to improve quality, safety and reduce costs. Production start-up is slated for the second half of 2020, subject to the timing of permits and construction.

Billy Cyr, Freshpet’s Chief Executive Officer commented, “Freshpet is changing the way people feed their pets. The rapid growth of the Freshpet brand behind our *Feed the Growth* strategy requires us to bring online additional capacity by mid-to-late 2020 to support our continued growth and enable us to serve more pets. It also allows us to provide more career opportunities for the dedicated and talented employees who have helped deliver the success we have had so far. We are very excited to have the opportunity to further advance our manufacturing expertise and expand our Freshpet Kitchens campus in Pennsylvania with the support of our local and state governments.”

“Pennsylvania is proud of the success of Freshpet and excited to be a part of its ongoing growth. We take particular pride in supporting the growth of companies that are true innovators and – as a result -- create sustainable long-term growth and high-quality manufacturing jobs for the people of Pennsylvania. And, through Freshpet’s focus on buying its ingredients locally, this expansion is good for Pennsylvania’s farmers and food ingredient processors who directly and indirectly supply Freshpet,” stated Pennsylvania Governor, Tom Wolf.

The facility expansion will result in the addition of at least 100 new manufacturing and support jobs over the next three years and up to a total of 200 new jobs once running at full capacity. Today, approximately 221 Freshpet employees are working on manufacturing, research and development (“R&D”) and other support roles on the Freshpet campus. Freshpet also expects the manufacturing expansion to increase the purchase of locally produced ingredients by approximately two-thirds and support additional jobs at local third-party warehousing and logistics providers. The facility will also include R&D space and a pilot plant facility to enable test runs of new products.

Freshpet’s planned expansion is being supported by state and local governments, including: Northampton County Industrial Development Authority Job Creation Grant; Pennsylvania First Program

Grant; Pennsylvania Job Creation Tax Credits; Pennsylvania Manufacturing Tax Credits and the Pennsylvania Workforce Development and PA Career Link training and education support.

About Freshpet

Freshpet’s mission is to improve the lives of dogs and cats through the power of fresh, real food. Freshpet foods are blends of fresh meats, vegetables and fruits farmed locally and made at our Kitchens in Bethlehem PA. We thoughtfully prepare our foods using natural ingredients, cooking them in small batches at lower temperatures to preserve the natural goodness of the ingredients. Freshpet foods and treats are kept refrigerated from the moment they are made until they arrive at Freshpet Fridges in your local market.

Our foods are available in select mass, grocery (including online), natural food, club, and pet specialty retailers across the United States, Canada and Europe. From the care we take to source our ingredients and make our food, to the moment it reaches your home, our integrity, transparency and social responsibility are the way we like to run our business. To learn more, visit www.freshpet.com.

Connect with Freshpet:

<https://www.facebook.com/Freshpet>

<https://twitter.com/Freshpet>

<http://instagram.com/Freshpet>

<http://pinterest.com/Freshpet>

<https://plus.google.com/+Freshpet>

<https://en.wikipedia.org/wiki/Freshpet>

<https://www.youtube.com/user/freshpet400>

Forward Looking Statements

Certain statements in this release constitute “forward-looking” statements. These statements are based on management's current opinions, expectations, beliefs, plans, objectives, assumptions or projections regarding future events or future results. These forward-looking statements are only predictions, not historical fact, and involve certain risks and uncertainties, as well as assumptions. Actual results, levels of activity, performance, achievements and events could differ materially from those stated, anticipated or implied by such forward-looking statements. While Freshpet believes that its assumptions are reasonable, it is very difficult to predict the impact of known factors, and, of course, it is impossible to anticipate all factors that could affect actual results. There are several risks and uncertainties that could cause actual results to differ materially from forward-looking statements made herein including, most prominently, the risks discussed under the heading “Risk Factors” in the Company's latest annual report on Form 10-K filed with the Securities and Exchange Commission. Such forward-looking statements are made only as of

the date of this release. Freshpet undertakes no obligation to publicly update or revise any forward-looking statement because of new information, future events or otherwise, except as otherwise required by law. If we do update one or more forward-looking statements, no inference should be made that we will make additional updates with respect to those or other forward-looking statements.

CONTACT

ICR

Katie Turner

646-277-1228

katie.turner@icrinc.com

Michael Fox

203-682-8218

Michael.fox@icrinc.com